



- RS-232 Compatible
- Selectable Baud Rate 1200bps – 38.4Kbps
- Range up to 600 Metres
- European Operation 868MHz
- RF Power 0-7 dBm
- Network Configurable
- Transparent or Data verified communications modes
- 4 User Configurable Digital I/O Channels
- Standard Hayes Command Set
- Internal LED indication of Power and Data TX & RX
- 12Vdc Power Supply
- Conforms to ETSI 300-220
- Requires no radio licence to operate
- Tough ABS enclosure



Description

The R.F. Solutions 232C-868FR1 radio modem provides fast and reliable RF data communications at an exceptionally competitive price. Whilst the RF modem is simple to use it is also highly adaptable and can be used in a wide variety of applications.

The modems can be configured for various operating modes to provide:

1. An 'invisible' RS232 point to point link, reproducing the function of a half duplex RS232 cable.
2. A RS232 point to point link with data flow control to provide data verification.
3. A functionality similar to that of a client/server network, where each modem is assigned an address with a maximum of 255 clients per network and a maximum of 65535 networks.
4. Point to point data transfer for up to four digital I/O signals with continuous resend and automatic data acknowledgement.

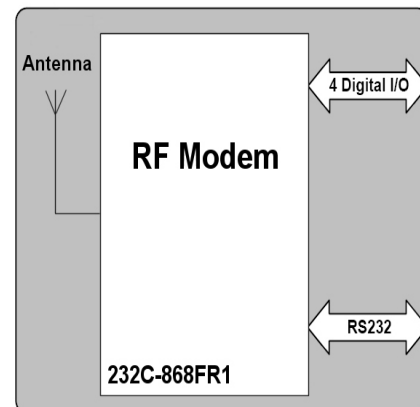

The modem is supplied in a tough ABS enclosure, with wall mounting lugs. The external 868MHz antenna offers a range of up to 600 metres line of sight. The modem is supplied with an RS232 cable and requires only a 9-12Vdc power supply.



Contents

1	Technical Specifications	3
1.1	Functional description	3
1.2	Status LED's	3
1.3	Connections	3
1.4	Electrical Characteristics.....	4
1.5	Temperature Range and Dimensions	4
2	Software Specifications.....	5
2.1	Operating modes	5
2.2	Quick Setup Guide	8
2.3	Hayes or 'AT' Mode	9
2.4	Standard commands description.....	9
2.5	Radio Test Commands	10
2.6	Registers description	10
3	Ordering Information	12





1 Technical Specifications

1.1 Functional description

The RF modem is software configurable using the standard AT command set. Commands can be entered via the RS232 port using a control device with communications software (for example a PC with windows HyperTerminal). Using this method the modem can be set to four different modes.

In transparent mode the modem provides an 'invisible' serial link and reproduces the function of a half duplex RS-232 cable. Transparent secured mode operates in the same manner of transparent mode and also provides data flow control to ensure the correctness of transmitted data frames. This provides the user with a fully data verified point to point communications link.

Addressed secured mode provides a functionality similar to that of a client/server network except that there is no server and all of the clients can communicate with each-other. Each modem is given an address with a maximum of 255 clients per network and a maximum of 65535 networks. In I/O copy mode the four digital I/O channels can be used to transfer TTL logic signals from one modem to another. As long as the modem remains in I/O copy mode the signals are automatically resent after a 1 second time-out with ensured reliability via automatic data acknowledgement. Detailed explanations of the available software modes are given in section 2.

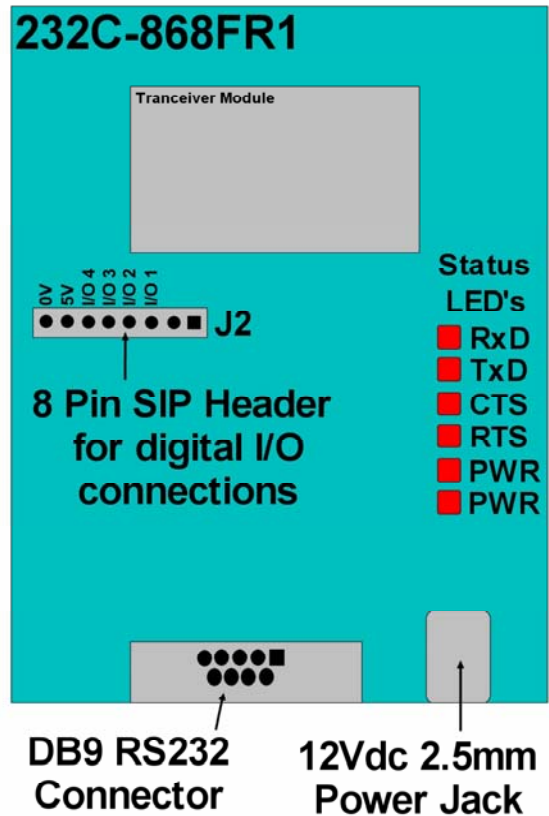

1.2 Status LED's

The RF Modem has six LED's, representing the following signals:

- TxD – Transmitting data
- RxD – Receiving data
- CTS – Clear to send data
- RTS – Ready to send data
- PWR – Power on

1.3 Connections

1.3.1 Digital I/O

When used in I/O copy mode four Digital I/O signals can be presented on the 8 pin SIP header on J2, as shown in the diagram above. Please refer to section 3.3 for control information when using the modem in I/O copy mode.

1.3.2 Power

The RF Modem requires a 9 - 12V @ 100mA power source. On the power jack the centre is +ve connection.



1.3.3 RS232 Connector

The RF Modem interfaces to the host computer via an RS232 connection using a standard DB9 connector as shown in the diagram below.

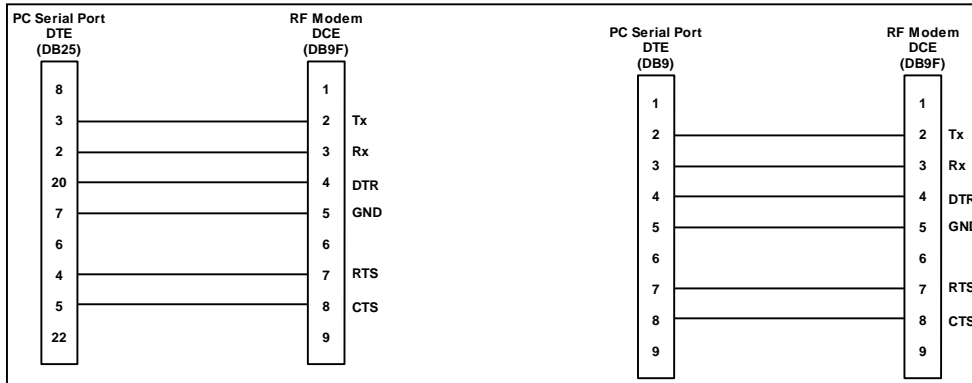

1.4 Electrical Characteristics

Specification	Conditions	Min	Typical	Max	Units
Channel center frequency	-		869.850		MHz
Aggregate air data rate	-		10		kbps
Modulation type	-		FSK		-
Range	Line of sight		800		m
Conformity testing / Standard	-		ETSI 300 220		-
Standby current consumption		0.004	0.006	0.020	mA
Receiving					
Sensitivity	CER <10-3		-101		dBm
Average CER	Input signal -50 dBm		<10-6		-
P1dB	CER <10-3		-10		dBm
Number of channels	-		1		-
Selectivity	At +/-150 kHz		36		dB
Current consumption		30.0	33.0	33.0	mA
Transmitting					
Output power @ Vcc = 12 V	-		7		dBm
Number of channels	-		1		-
Current consumption		27.0	30.0	33.0	mA

1.5 Temperature Range and Dimensions

Storage Temperature: -40°C to +85°C.
 Operating Temperature: -10°C to +55°C with full specification characteristics
 -20°C to +85°C with performance deteriorated

Enclosure dimensions: 110mm x 85mm x 35mm
 PCB dimensions: 99mm x 74mm





2 Software Specifications

2.1 Operating modes

The RF modem is able to operate in four different modes which can be configured by setting register values using AT commands. Sections 2.2 - 2.4 give a full explanation of how to program the registers, the operation of the different modes is explained in detail in the following paragraphs.

2.1.1 Transparent Mode

In Transparent Mode, the RF modem behaves like a wired serial link, i.e. the modem does not only transmit to the radio channel every data received on the serial link, but also transmits on the serial link the information received on the radio channel.

Basically the RF modem reproduces the half-duplex function of a RS-485 cable.

There is no flow control performed by the modem in the transparent mode, neither on the serial link nor on the radio link. Flow control must be carried out by software applications via various protocols in use such as MODBUS, JBUS, etc...

Consequently, in Transparent Mode it is not possible to change the modems parameters without a temporary return to Hayes mode.

NOTE: The user's software application must adequately verify that all buffers are transmitted correctly taking into account that an interrupted transmission link may lead to losing one or several buffers.

2.1.2 Transparent Secured Mode

In order to confirm the correctness of the transmitted data frames, data flow control between the modems is added to the Transparent Mode, so that each data transfer is "data verified". This mode shall be operated for point-to-point communications only.

Transparent Secured Mode or Transparent «Data Verified» Mode's purpose is to offer an optimal radio link quality and to provide transparent mode with the necessary security in case flow control would not be included within the user's application software.

The risk of data loss is much lower than during the use of application software only because this latter is dependent on the intermediate times inserted by the serial link.

Moreover, a flow control is performed on the serial link in order to warn the user that the buffer (including 132 characters) is saturating. The warning level is default set to 132 characters and can be programmed via register S218.

NOTE: The user's software application must adequately verify that all buffers are transmitted correctly taking into account that an interrupted transmission link may lead to losing one or several buffers. After N Time repetition of a buffer (N programmable up to 255 with S223) without a correct acknowledgement the buffer shall be considered as lost.

2.1.2.1 «Secured» link Algorithm

The transmitting modem proceeds to data framing:

- Transferred Data Count up.
- Transferred Data Frame Type.
- Frame number.
- Data to be transmitted.
- 16 bits Checksum.

The receiving modem analyses this data frame and checks its consistency.

When the data frame is received correctly, the receiver transmits an acknowledgement back to the transmitter, and delivers the received data framing to its serial link.

In case the reception is not without errors, the receiver requests a new framing transmission to the transmitter. The number of repetitions depends on the parameter programmed in the modem configuration (Register S223).

At serial port level, each transmitted data frame is «Data Verified», but no statement asserts to the user whether the data frame has been transmitted yet or not.



In «Transparent Secured Mode», a time-out is defined to indicate the end of a frame. This time-out is a programmable parameter (Register S214) separating each frame from the next one.

2.1.3 Flow control

Two types of flow control are available:

- Hardware: CTS/RTS (the modem manages RTS signal only).
- None

Register S216 can be used to program this parameter:

- '0' stands for hardware flow control.
- '2' indicates no flow control.

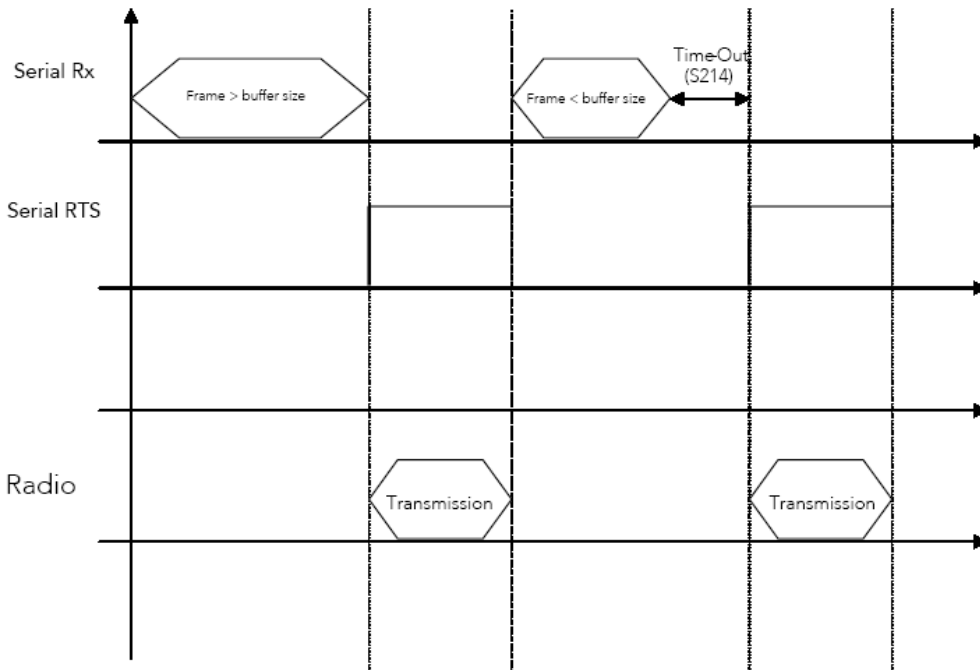

Figure 5-1: Flow Control Timing Diagram

2.1.4 Addressed Secured Mode

The Addressed Secured Mode is similar to a client/server network mode, the difference is that there is no server and all clients can communicate with each other.

Addressed secured mode's purpose is to offer an optimal radio link quality and to provide transparent mode with the security of the secured mode. This transparent addressed secured mode includes the additional feature to use an address field to address one particular client.

Data Management is as follows:

- Data transmissions are fully «Data Verified».
- The modem acts as in transparent mode, adding frame encapsulation.
- Identification of clients with a specific number added at the beginning of each data frame.

Example: "1=Hello" sends the data frame "Hello" to Client No.1.

- The receiver client recognises the client transmitting modem by the number starting the data frame.

Example: "002=Hello" indicates that data frame "Hello" comes from Client No.2. o



The I/O Copy mode stops as soon as the modem returns to Hayes mode (+++ command).

2.2 Quick Setup Guide

The 232C-868FR1 is supplied with all its settings in the default values. It can be used with bundled MTC workbench software to establish a simple transparent point to point link by following the steps outlined below.

1. Install the MTC workbench software, supplied on the bundled CD onto your PC.
2. Connect your modem to the COM port of your PC using the supplied RS232 cable, apply power to the modem and load the MTC workbench software. The PWR and RTS LEDs will now be on.
3. When prompted to launch auto-configuration select 'Yes'. The modem will now be automatically detected by the software program.
4. In the *Settings* menu change the user level to advanced. Now repeat auto-configuration by selecting the option from the *Modem* menu.
5. From the *Tools* menu select *Terminal* and open a terminal window on the COM port connected to the modem. You can now type text into the terminal window, if the Port is opened (By pressing the 'Open Port' button) then the text data will be sent over the serial link to the modem, as shown opposite.
6. Repeat steps 1-5 using either another PC or a different COM port on the same PC.
7. If the configuration settings are the same for both modems then you should now be able to wirelessly send text from one COM port to the other.

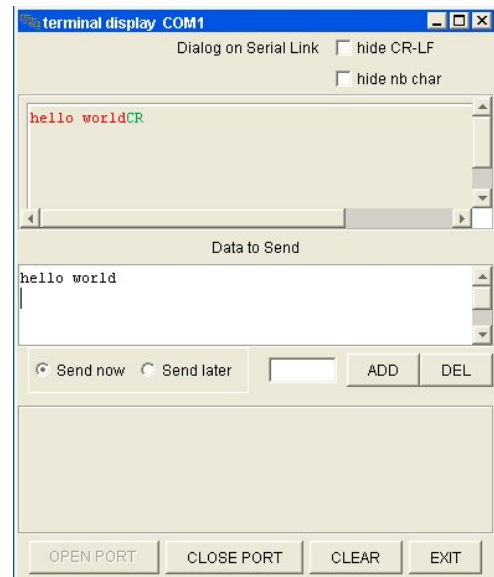

Notes

For full instructions on the use of the MTC workbench software please refer the manual provided on the CD bundled with the modems.

The modems configuration settings can be changed by double clicking on the modem name, 'B868-tiny' under the COM port in the *tree* window. Once you have changed the settings to those which you require they can be propagated through to the modems registers by clicking on the *Apply* button.

You can also change the configuration settings by entering AT commands into the terminal window in MTC workbench. Please refer to section 2.3 below for a description of the AT commands available.



2.3 Hayes or 'AT' Mode

The Hayes or 'AT' commands comply with the Hayes protocol used in PSTN modem standards. This 'AT' protocol or Hayes mode is used to program the modem parameters, based on the following principle:

- A data frame always begins with the 2 ASCII 'AT' characters, standing for 'ATtention'.
- Commands are coded over one or several characters and may include additional data.
- A command is always ended by a <CR> Carriage Return.

A	T	Command	Additional command	...	<CR>
---	---	---------	--------------------	-----	------

Note: Register numbers and values used in the AT commands are in decimal format.

The only exception to this data-framing rule is the command to enter the enter AT-mode. In this case, only the escape code ('+++') by default) must be typed and followed by a silent time at least equal to the time out. <AT> and <CR> shall not be used.

Note: All characters of the same command must be typed in quickly to prevent a timeout before the whole command has been entered. Alternatively commands can be cut and paste from notepad to ensure the whole command is entered within the time limit.

Note: Generally a successful AT command will return 0 and an unsuccessful command will return E.

Despite its similarity to standard telecommunication modems, the 232C-868FR1 remains a radio link modem and is consequently fitted with some particular additional "AT" commands.

2.4 Standard commands description

- '+++'** **Enter AT-mode.**
 This command gives an instant access to the modem parameter set-up (Hayes or AT-mode), whatever the actual operating mode in process might be. This command shall not be started with AT, but by a silent time duration whose parameter entering is defined in milliseconds in Register S214. N.B.: By activating the AT-mode, the modem inactivates radio reception.
- 'ATO'** **Exit AT-mode**
 This command activates the operating mode as stored into register S220.
- 'ATSn?'** **Display value of register n.**
 The modem operating parameters are stored in 'S' classified Registers. S Registers are numbered from 0 to 512. Some parameters are standard for every Hayes type modems, other are specific to the 232C-868FR1 modem (See section 2.6 for register descriptions). Operating parameters are stored in EEPROM memory and automatically set-up during modem reset and modem turn on.
- 'ATSn=m'** **Change value of register n to m.**
 Changed values of registers are automatically stored in the modem EEPROM memory.
- 'AT/S'** **Display values of Significant Registers.**
 All significant registers for the modem (radio configuration, serial configuration, operating mode,) are sent to the serial link, ready to be displayed by software like Windows HyperTerminal.
- 'AT/V':** **Display values of the Modem Software version.**





Information concerning the version number and installation date is sent on the Serial Link; ready to be displayed by Software like Windows HyperTerminal.

'ATR': Hayes registers reset to default values

This command allows the user to reset ALL the stored EEPROM registers to their default values (see registers description below).

'ATP': Switch to Stand-by mode

This command allows the user to switch to Stand-by mode. The Modem is in Normal Mode by default. The Modem switches back to Normal Mode with a character reception from the Serial link.

2.5 Radio Test Commands

These special AT commands are integrated into the RF modem in order to make measurements during continuous transmission, and are primarily used during radio tests (radiated power, bandwidth, etc.) to show conformance to the ETS 300 220 standard.

It stops when any character is sent:

- ATT0 <CR>: Transfer of a pure carrier '0'
- ATT1 <CR>: Transfer of a pure carrier '1'
- ATT2 <CR>: Transfer of a modulated carrier at F(maximum)
- ATT3 <CR>: Transfer of a modulated carrier at F(average)
- ATT4 <CR>: Transfer of a modulated carrier at F(minimum)

2.6 Registers description

The RF modem can offer several possible configurations using a set of parameters. Those parameters are located in registers and have a default value. This value can be modified or consulted via Hayes commands.

The parameters of the radio modem are stored in the EEPROM and can therefore be changed up to 10,000 times. The parameters are available when switching on the modem. The registers are listed below:

Radio			
Access	Register	Name	Description
R/W	S204	Carrier Length	Indicates the radio carrier length in milliseconds, sent at the beginning of each radio frame. Valid between 4 and 50 milliseconds. Default value: 15ms

Serial Link			
Access	Register	Name	Description
R/W	S210	Baud Rate	Indicates the serial link rate: <i>Value Rate</i> '1' -> 1200 Bits/s '2' -> 2400 Bits/s '3' -> 4800 Bits/s '4' -> 9600 Bits/s '5' -> 19200 Bits/s (Default value) '6' -> 38400 Bits/s
R/W	S211	Data Length	Indicates the number of data bits on the serial link: '7' -> 7 data bits. '8' -> 8 data bits (Default value)





RS232 RADIO MODEM

232C-868FR1

R/W	S212	Parity	Indicates the parity on the serial link: '1' -> No parity (default value) '2' -> Even Parity '3' -> Odd Parity
R/W	S213	Number of Stop Bits	Number of Stop bits on the serial link: '1' -> 1 Stop bit (default value) '2' -> 2 Stop bits
R/W	S214	Time-out	Time-out in milliseconds on the serial link. Valid between 2 and 100 milliseconds. Default value: 5 ms
R/W	S216	Flow Control	Indicates the flow control mode: '0' -> RTS/CTS '2' -> None (Default value)
R/W	S218	Buffer size	Indicates the maximum size of frames. When this maximum size is reached, the modem switches the CTS signal. Valid between 30 and 245 bytes. Default value: 245 bytes

Operation			
Access	Register	Name	Description
R/W	S220	Operating Mode	Indicates the operation mode of the modem. '1' -> Transparent (Default value) '3' -> Transparent Secured '6' -> Master I/O '7' -> Slave I/O '9' -> Addressed Secured '10' -> Demo mode – master '11' -> Demo mode – slave
R/W	S221	Autorepeat	Indicates auto-repeat status in transparent mode (i.e. whether the modem automatically replies a data frame) '0' -> Autorepeat off (Default value) '1' -> Autorepeat on
R/W	S223	Number of Retries	Indicates the maximum number of retries when a message contains errors in secured mode. Valid between 0 and 255 (modulo 256). If the value is '0', frames are not checked and considered as good (used for tests). Default value: 2

Addressed Management			
Access	Register	Name	Description
R/W	S250	Network Number	Indicates the network number using 2 bytes. Only members of the same network can communicate together. Valid between 0 and 65535 (modulo 65536), it is set to '0' when the modem is not initialised. NB: Setting S250 to '0' also sets S252 to '0'. Default value: 0



