



Features

- Miniature SIL Package
- Fully Shielded
- Data Rates Up To 64kbits/S
- Range upto 200 Metres
- Single Supply Voltage
- Industry Pin Compatible

QFMT6-XXX

- Temp range $-20^{\circ}\text{C} + 55^{\circ}\text{C}$
- European Versions;
- 868.4 MHz for 10% duty cycle band
- 869.85 MHz for 100% duty cycle band
- American version;
- 915.0MHz
- Bandwidth Efficient PLL technology

QFMR6-XXX

- Single conversion FM superheteodyne using RF
- SAW and ceramic IF filtering at 10.7 MHz
- Image rejection 60dB
- Analogue, digital outputs
- Signal strength output (RSSI)
- Incorporates AGC for improved dynamic range
- Dynamic range better than 120dB
- Single 5V supply

Applications

- Vehicle Alarm Systems
- Remote Gate Controls
- Garage Door Openers
- Domestic And Commercial Security

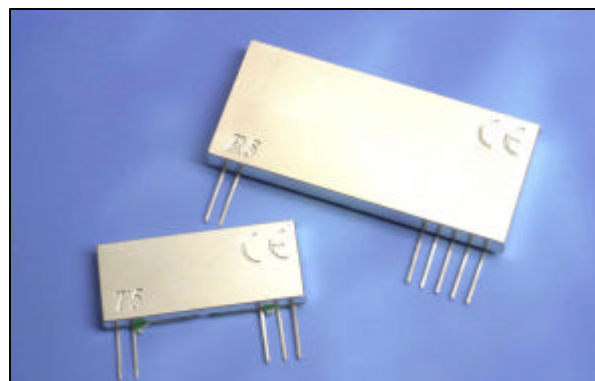

Description

The QFMT6 AND QFMR6 miniature UHF radio modules enable the implementation of a reliable telemetry link at data rates of up to 64 Kbits/s.

The QFMT6 is based on a classical phase lock loop using a crystal reference oscillator. This results in an accurately controlled RF output in the frequency domain. A significant advantage of this is that narrow filtering can then be used in the receiver, which results in high interference immunity.

In addition, the modules are fitted with an on-board voltage regulator which enhances performance from improved supply filtering and also ensures a constant RF output level.

The QFMR6 is based on the single conversion superhet principle utilising a crystal based phase lock loop for accurate generation of the local oscillator. This allows use of high Q bandpass filters resulting in good adjacent channel selectivity and high interference immunity.

The QFMT6 and QFMR6 modules will suit one-to-one and multi-node wireless links in applications including building and car security, remote industrial process monitoring and computer networking. Because of its small size and low power requirements, these modules are ideal for use in portable battery powered wireless applications. These modules may be used within areas of high interference, or 'radio traffic'. Due to the design, they provide a highly reliable radio link.

Connection Diagram / Dimensions QFMT6 Transmitter

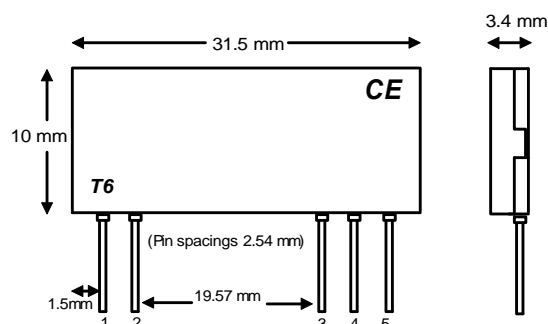

Pin Descriptions

RF GND (*pin 1*)

RF Ground pin is internally connected to pin 4 (0V) This pin should ideally be connected to the nearest ground plane (e.g. coax braid, main PCB ground plate etc.)

RF OUT (*pin 2*)

50Ω RF antenna output. To achieve best results the antenna impedance must match that of the module.

V_{CC} (*pin 3*)

+Ve supply pin (3.0 to 9.0 volts). The module will generate RF when V_{CC} is present. It is strongly recommended that a 100nF capacitor decouples the supply rail as close as possible to this pin.

GND (*pin 4*)

Supply and data ground connection, connected to pin 1.

Data IN (*pin 5*)

This input has an impedance of 47KΩ and should ideally be driven by a CMOS logic drive or compatible. The drive circuitry should be supplied with the same supply voltage as the Tx module.

Ordering Information:

Part No	Description
T6-8684-20	SIL Transmitter 868.4MHz 20Kbps Data rate
T6-8684-64	SIL Transmitter 868.4MHz 64Kbps Data rate
T6-86985	SIL Transmitter 869.85 MHz
T6-915-20	SIL Transmitter 915.0 MHz 20Kbps Data rate
T6-915-64	SIL Transmitter 915.0 MHz 64Kbps Data rate

**Absolute Maximum Ratings: Transmitter QFMT6**

Operating temperature: -20°C to +55°C

Storage temperature: -40°C to +100°C

Supply Voltage (pin 3) 10V

Data input (pin 5) 10V

Electrical Characteristics: Transmitter QFMT6

	Pin	Min.	typ.	Max.	units	notes
Supply voltage	3	2.3	5.0	10.0	Volts	
Current & RF POWER						
868.40 MHz						
Supply current @ $V_{CC} = 5V$	3		7		mA	1
RF power	2		1		mW	1
RF & Data						
2 nd harmonic			-50		dBm	2
Harmonics @ > 1GHz			-50		dBm	2
Initial frequency accuracy			±10		KHz	
Modulation bandwidth @ -3dB			35		KHz	
Power up time to full RF			10		mS	
Data rate		100		64000	bits/s	
Data pulse width		15			µS	

Notes

1. Measured into a 50Ω impedance a 10mW version is planned for production
2. The limit for the European spec EN 300 220 is -36dBm

Connection Diagram / Dimensions QFMR6 Receiver

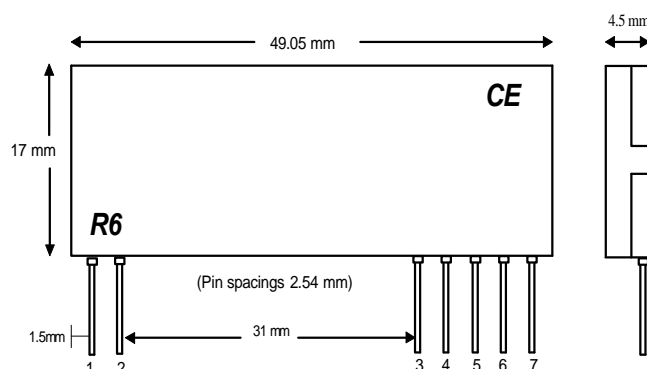

Pin Descriptions

RF IN (pin 1)

50 Ω RF input from antenna, connect using shortest possible route. This input is isolated from the internal circuit using the air gap of the front end SAW RF filter

RF GND (pin 2)

RF ground connection, preferable connected to a solid plane.

RSSI / Carrier Detect (pin 3)

The Received Signal Strength Indicator provides a DC output voltage proportional to the RF input signal. The amplitude of the RSSI voltage increases with increasing RF signal strength. A simple transistor interface can yield a carrier detect logic output.

GND (pin 4)

Connect to power supply ground.

V_{CC} (pin 5)

+Ve supply pin. Operation from a 5V supply able to source 6mA at less than V_{p-p} ripple.

AF (pin 6)

Audio frequency output. (max 40uA source)

DATA OUT (pin 7)

CMOS compatible output. This may be used to drive external decoders. To reduce any noise on this output add a 56pF cap from this pin to GND.

Ordering Information:

Part No	Description
R6-8684-20	SIL Receiver 868.40 MHz 20Kbps Data rate
R6-8684-64	SIL Receiver 868.40 MHz 64Kbps Data rate
R6-86985	SIL Receiver 869.85 MHz
R6-915-20	SIL Receiver 915 MHz 20Kbps Data rate
R6-915-64	SIL Receiver 915 MHz 64Kbps Data rate

**Absolute Maximum Ratings: Receiver QFMR6**

Operating temperature: -10°C to +55°C
 -40°C to 80°C option available

Storage temperature: -40°C to +100°C

Supply Voltage (pin 5) 7V
 RF Input (pin 1) +20dBm (100mw)

Electrical Characteristics: Receiver QFMR6 (20 Kbits/s version)

	min.	typ.	Max.	units	notes
Supply voltage	4.5	5.0	5.5	V	
Supply current		6		MA	
Supply ripple			10	mV _{p-p}	
Data output high		=>4.0		V	
Data output low		<=0.5		V	
RF					
RF sensitivity		-103		dBm	
IF Bandwidth		230		KHz	1
Initial signal accuracy		±10		KHz	
Max. RF input		20		dBm	
E.M.C					
Spurious responses upto 1GHz		<60		dB	
LO leakage, conducted		<60		dBm	
LO leakage, radiated		<60		dBm	
Image rejection		60		dB	
Dynamic Timings					
Power up to stable data (With RF signal present)		6		mS	2
Signal to stable data (With power supply already on)		5		mS	2
Power up to valid RSSI (With RF signal present)			1	mS	2
Mark : space ratio		50		%	
Bit rate	100		20000	bps	

Notes

1. IF bandwidth available down to 27KHz.
2. Timings are to be confirmed

Antenna Design

The design and positioning of the antenna is as crucial as the module performance itself in achieving a good wireless system range. The following will assist the designer in maximising system performance.

The antenna should be kept as far away from sources of electrical interference as physically possible. If necessary, additional power line decoupling capacitors should be placed close to the module.

The antenna 'hot end' should be kept clear of any objects, especially any metal as this can severely restrict the efficiency of the antenna to receive power. Any earth planes restricting the radiation path to the antenna will also have the same effect.

Best range is achieved with either a straight piece of wire, rod or PCB track @ $\frac{1}{4}$ wavelength. Further range may be achieved if the $\frac{1}{4}$ wave antenna is placed perpendicular in the middle of a solid earth plane measuring at least 16cm radius. In this case, the antenna should be connected to the module via some 50 ohm characteristic impedance coax.

Loop Antenna

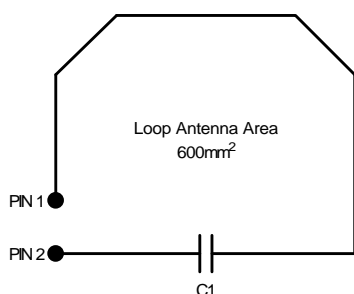

C1 = 1pF @ 433MHz
C1 = 1pF @ 868MHz and halve loop area

Loop Antenna: The loop antennae, is the cheapest and most compact of the three antennas. The antenna always takes up the form of a track on a PCB, the antenna consists of a feeder capacitor C1 which is connected directly to the transmit pin on the radio module, and a loop track which is grounded. This antenna gives the poorest performance of the three, and thus is essential that the tuning capacitors are adjusted for the best system performance.

Helical Antenna

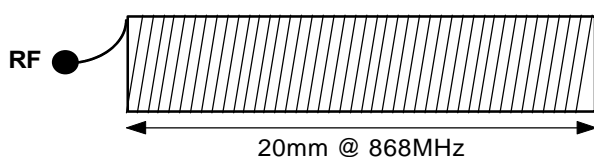

Ø = 5mm (inside)

Helical Antenna: The helical antenna provides a more compact antenna for mobile radio systems. The antenna must be connected directly to the transmit pin of the radio module.

Whip Antenna

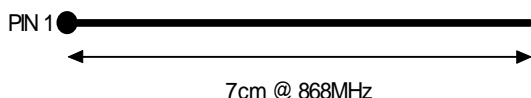

Whip Antenna: The whip antenna simply consists of a metal rod with a length of $\frac{1}{4}$ of the wavelength of the signal which you wish to transmit. The whip must be directly connected to the transmit pin on the module.

Application Circuit

The application circuits show how the QFMT6 transmitter and the QFMR6 receiver can easily be integrated into a system to form a wireless link.

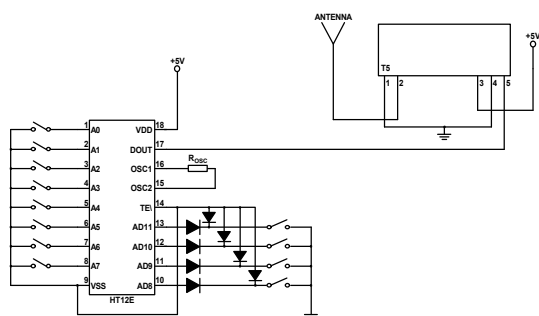

Figure 3: QFMT6 Quasar Transmitter Application Circuit

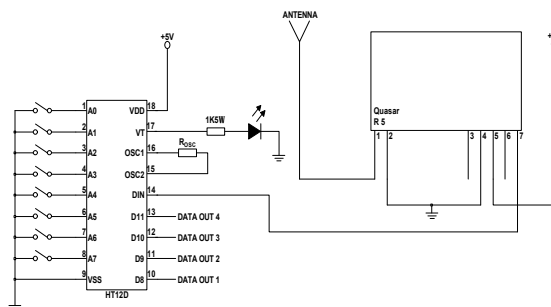
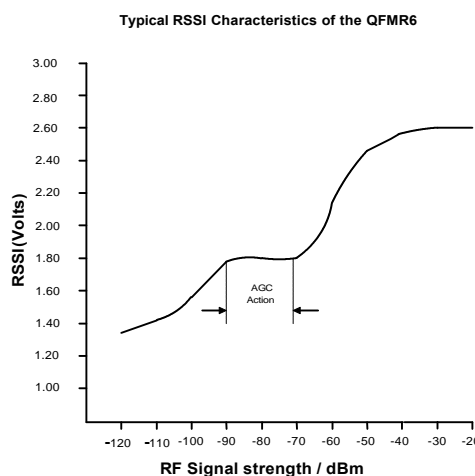

Figure 4: QFMR6 Quasar Receiver Application Circuit

RSSI Values:

The QFMR6 RSSI output provides a DC output proportional to the RF input signal. The table shows the typical RSSI value depending on the RF signal strength

RF Signal Strength / dBm	RSSI / V
-120	1.35
-110	1.41
-100	1.57
-90	1.79
-80	1.8
-70	1.8
-60	2.15
-50	2.45
-40	2.58
-30	2.59
-20	2.59



Note that the region between -90 and -70 is with receiver AGC (automatic gain control) operating. If required, a receiver version with AGC disabled can be provided as a factory pre-set option. This would linearise the RSSI curve.

For more information or general enquiries, please contact

**Finchdata Ltd Grove House Lutyens Road
Basingstoke RG24 8AG.**

Email :sales@Qradio.co.uk <http://www.Qradio.co.uk>

Tel: +44 (0)870 746 0895 Fax: +44 (0)870 131 7493

Finchdata Ltd is a trading partner of Rf solutions Ltd.